

FL-400-series
Maximum Security
Aluminum Flush Door Entrances
Product Details



Details:

- FL-400-series door line is our most versatile door line.
- Unique aluminum extrusion plank design maximizes strength, security, and design options.
- Door face thickness is 1/8" with 1/4" internal reinforcement wall every four inches. Hinge and lock edge thickness is 3/16".
- Doors are 1-3/4" thick.
- Doors are insulated with 1-1/2" polyisocyanurate rigid foam insulation. "R" value 11.23 and "u" factor .089.
- Standard doors have three 3/8" diameter tension rods thus giving additional strength in middle of door.
- Made with aluminum extrusions, which has approximately 4 times the yield and tensile strength of aluminum sheets.
- Unlimited design possibilities and hardware options.
- Fluted (standard) and smooth skin patterns available.
- Infills range from 1/4" to 1-5/16".
- Top and bottom of door capped.
- Virtually maintenance-free construction.
- Forced entry tests(AAMA 1304) are nearly double the standard requirements.
- Wind loads (ASTM E330) readings of 6840 Pa (142.86 psf).
- Custom and standard anodized, painted, and wood grain finishes.
- UltraFab's UltraFin weatherseals for meeting stiles and framing door stops.
- Unlimited rail sizes and configurations available.
- Numerous muntin details available.
- Non-removable exterior glazing leg for ultimate security.
- Glazed door panels available.
- Concealed card readers available.
- Hurricane, historical, and "blinds in glass" glazing kits available.

Product Uses

- FL-400-series doors are designed for a wide range of uses from maximum security military installations, high traffic main entrances at schools and public buildings, to back street alley maintenance and utility entrances.
- Other areas of common use: Water treatment plants, banks, stores, government buildings, restaurants, hotels, utilities buildings, YMCAs, indoor pool doors, greenhouses, aquatic centers, high end gate doors.

FL-400-SERIES

Standard Configurations

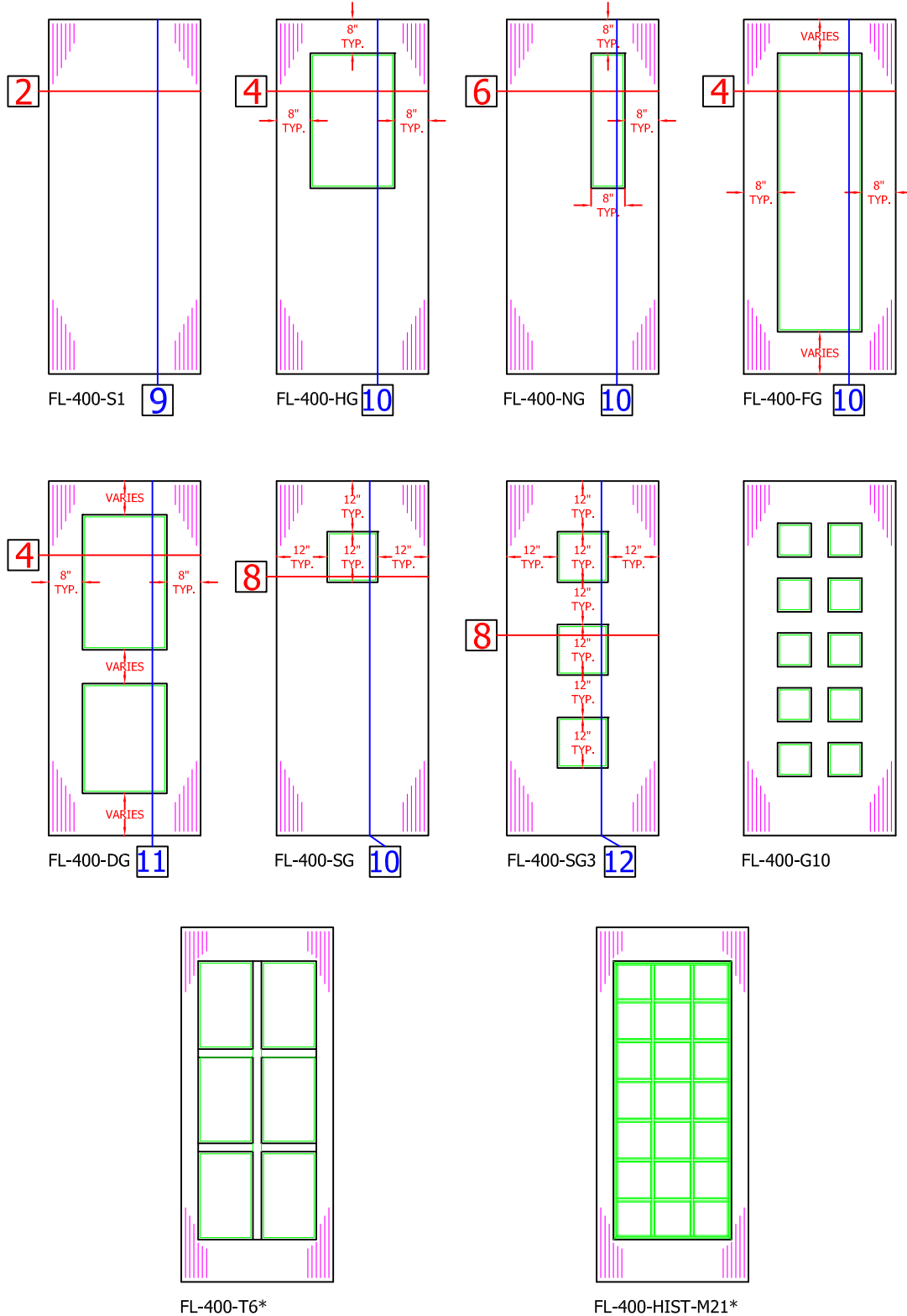

NOTE: *INSULATED PANELS AVAILABLE IN FLUTED AND SMOOTH PATTERNS.
 *DOORS WITH *M* IN LAST SERIES OF DIGITS HAVE SURFACE APPLIED MUNTINS OR MUNTINS INSIDE GLASS. CUSTOM MUNTIN PATTERNS ARE AVAILABLE.
 *DOORS WITH *T* IN LAST SERIES OF DIGITS HAVE TRUE 2" EXTRUDED MUNTINS.
 *DOORS WITH *HIST* DESCRIPTION USE HISTORICAL TRIM OPTION.
 *ANY NUMBERS IN THE LAST SETS OF DIGITS NOTE THE NUMBER OF DOOR LITES IN DOOR.

FL-400-SERIES

Concept Configurations

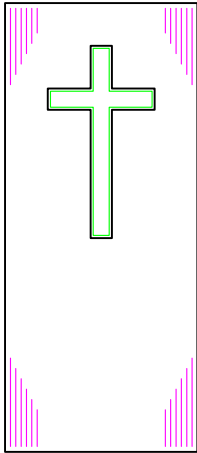

FL-400-CROSS

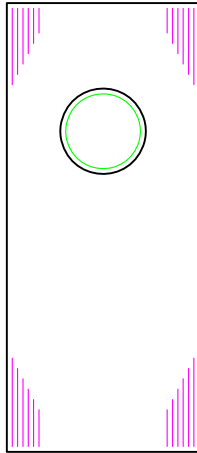

FL-400-CG

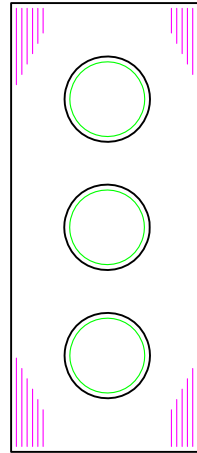

FL-400-CG3

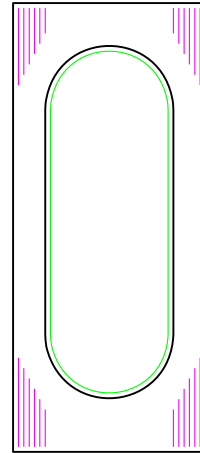

FL-400-OG

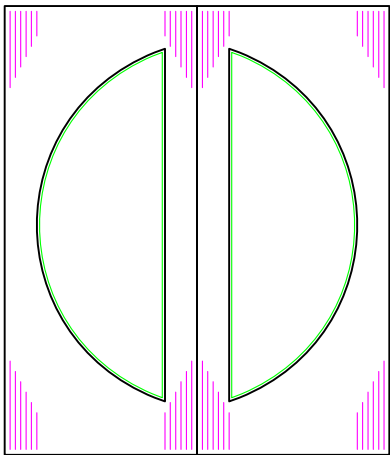

FL-400-HMG

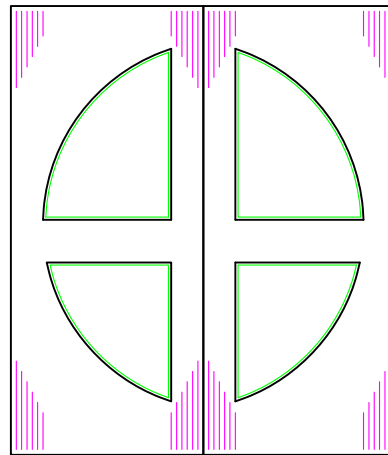

FL-400-HMG-MID

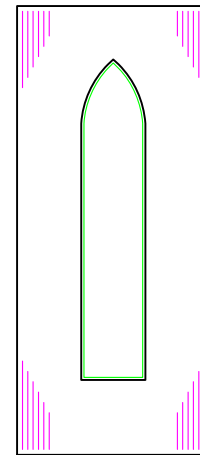

FL-400-AG

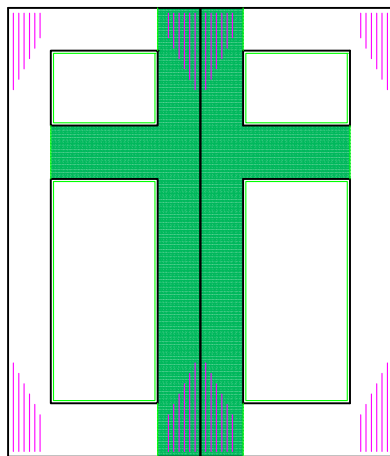

FL-400-CROSS-P2

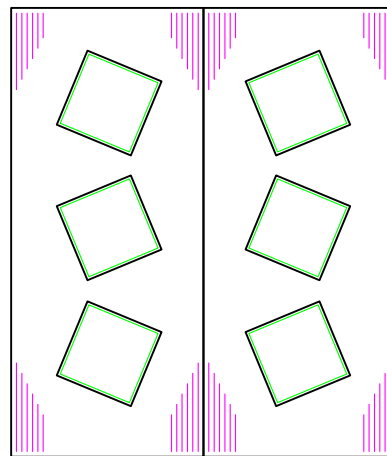

FL-400-SHAKE IT UP

FL-400-SERIES

Stile Details

FL-400-S1 - Pair of Doors

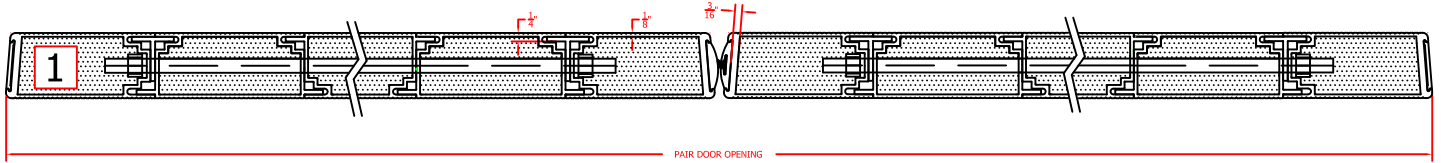

FL-400-S1 - Single Door

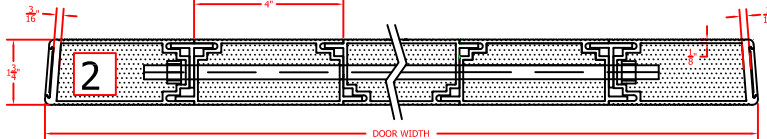

FL-400-HG/FG/DG - Pair of Doors

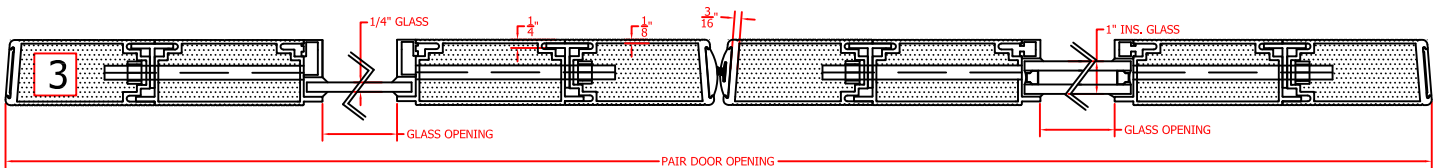

FL-400-HG/FG/DG - Single Door

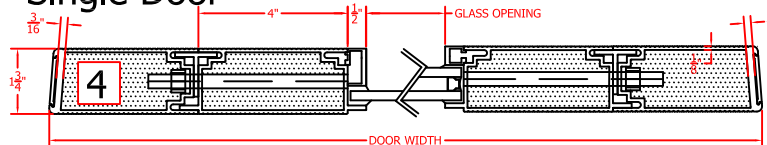

FL-400-NG - Pair of Doors

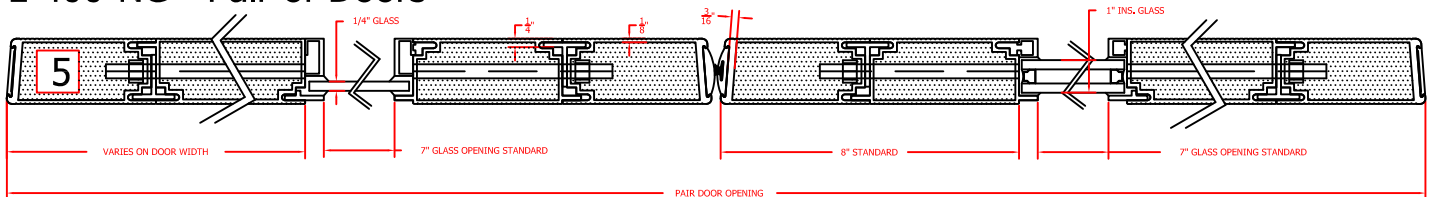

FL-400-NG - Single Door

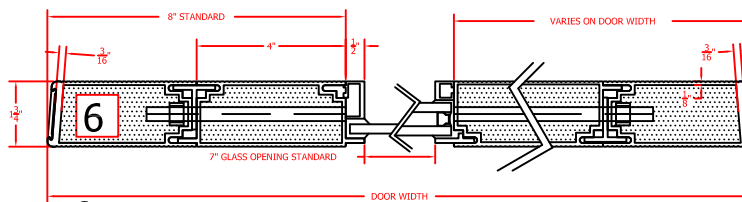

FL-400-SG/SG3 - Pair of Doors

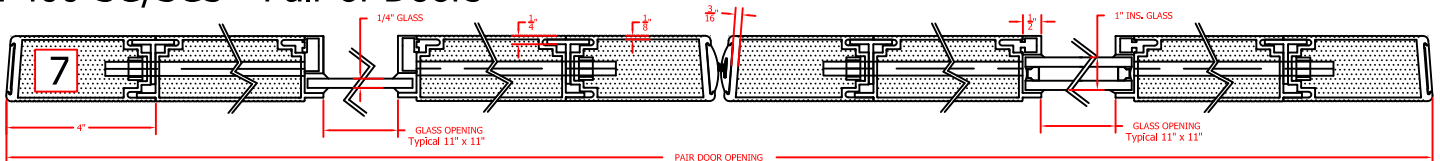

FL-400-SG/SG3 - Single Door

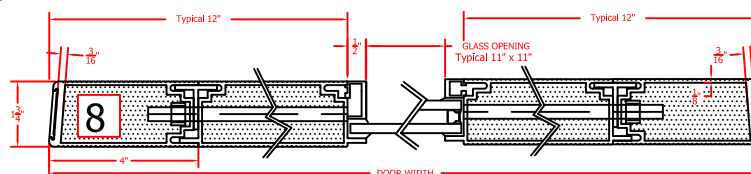

FL-400-SERIES

Rails

FL-400-HG/FG/SG

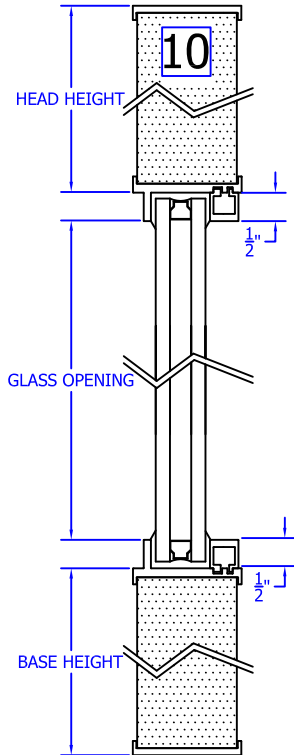

FL-400-S1

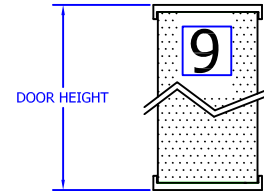

FL-400-SG3

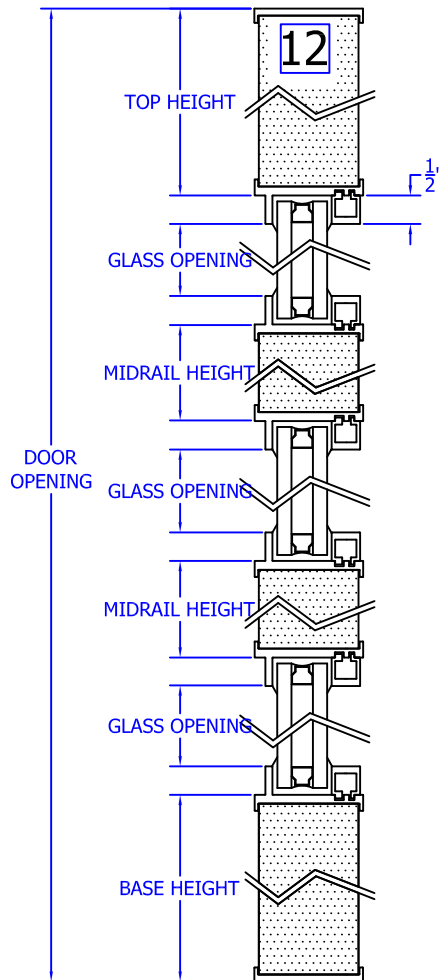

FL-400-DG

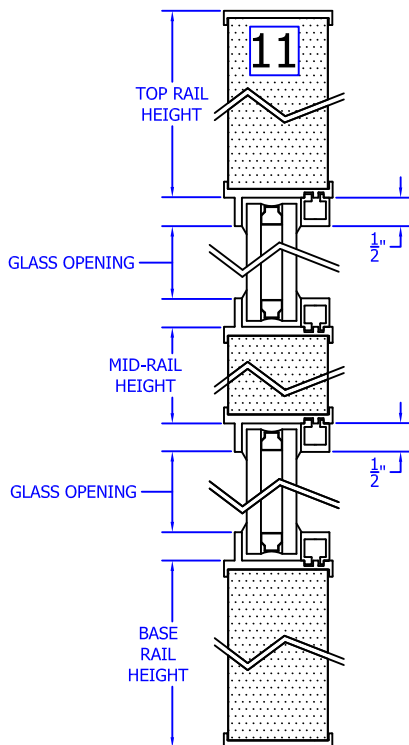

FL-400-Series Glazing Stops



Removable Door Glazing Stops

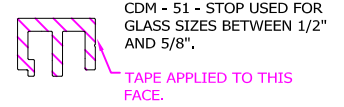
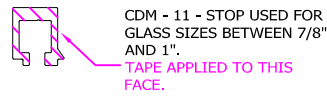
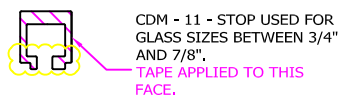

Door Glazing Tape Guide

- GT-316 COMES IN 50FT ROLLS (STANDARD) - THICKER TAPE
- GT-18 COMES IN 100 FT ROLLS
- GT-116 COMES IN 200 FT ROLLS (STANDARD) - THINNER TAPE

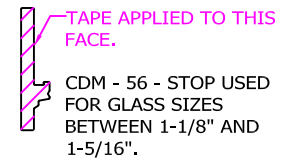

STANDARD

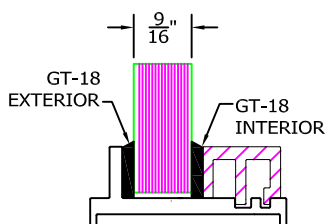
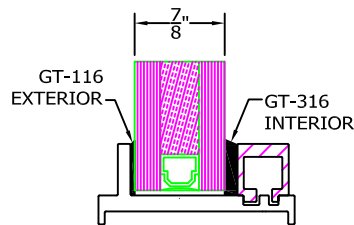
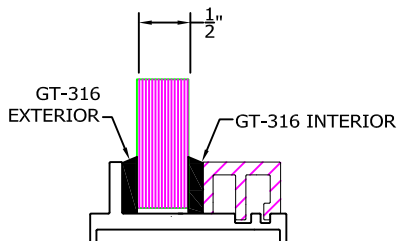
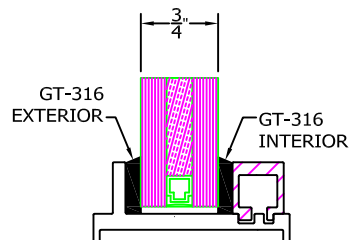
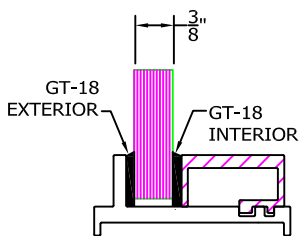
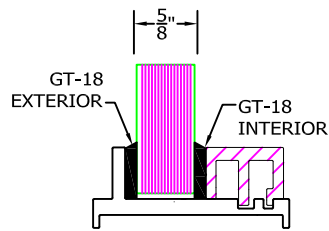
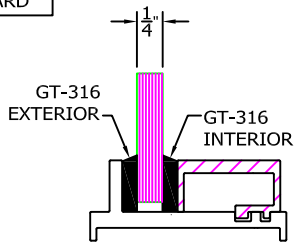

STANDARD

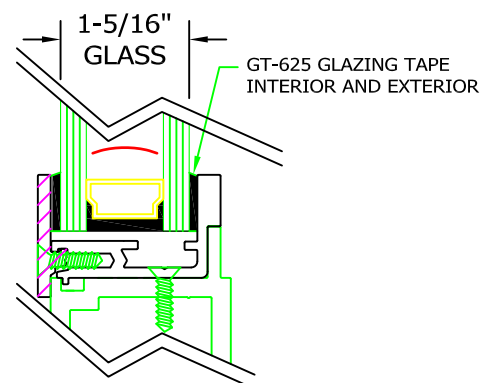
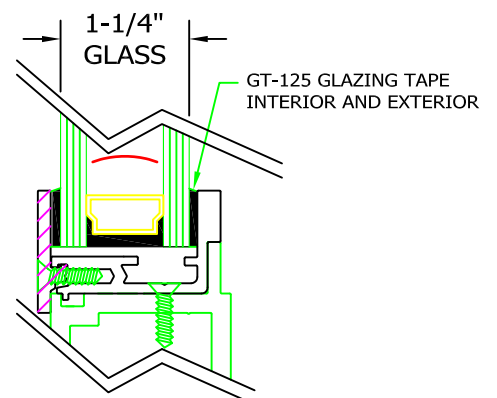
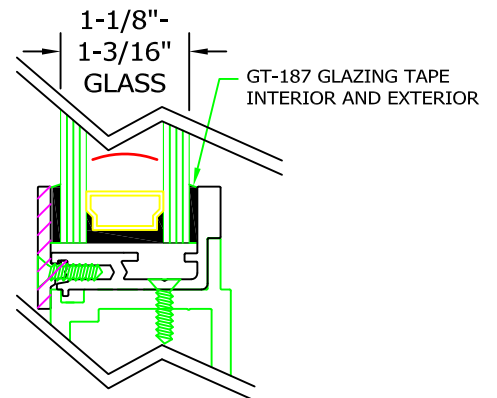
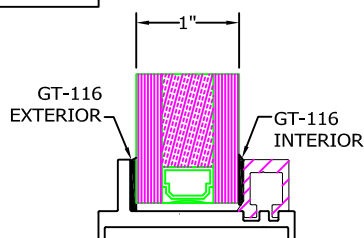

FL-400-SERIES

General Helps

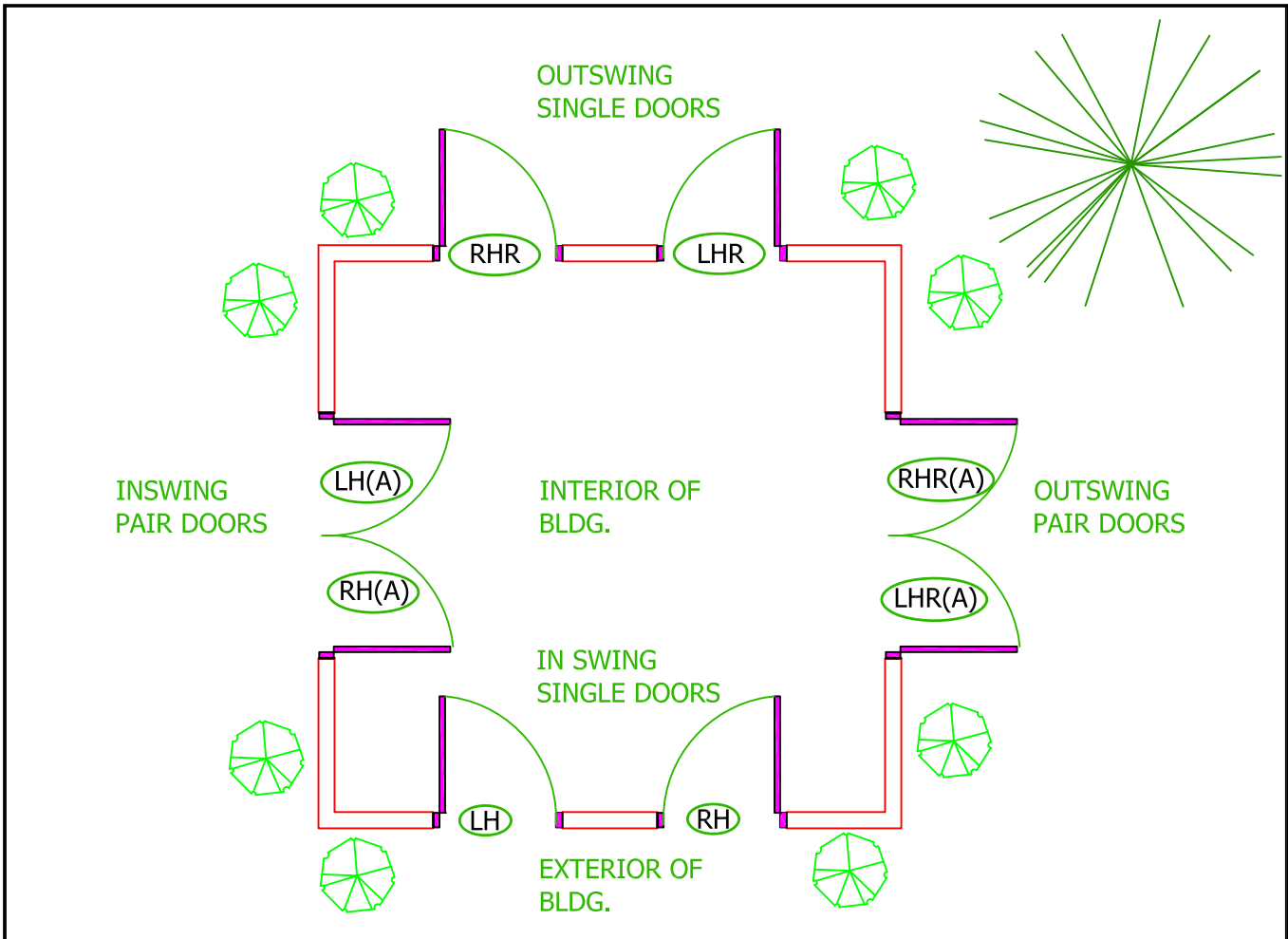

FINDING DOOR SWINGS USING A FLOOR PLAN.

NOTE: ON PAIR DOORS, ONE DOOR LEAF IS USUALLY SELECTED AS THE ACTIVE LEAF. THIS IS DONE BY ATTACHING A LETTER A AT THE END OF THE ACTIVE DOORS HANDING.

OTHER IMPORTANT FACTORS FOR ALUMINUM DOOR AND FRAME SPECS.

- *IF NOT NOTED IN SHOP DRAWINGS, IT IS IMPORTANT TO REQUIRE FIELD MEASUREMENTS BEFORE FABRICATION.
- *REQUIRE COLOR SAMPLES FOR CUSTOM COLORS.
- *REQUIRE DOOR MANUFACTURER TO PROVIDE AT LEAST IMMEDIATE DOOR FRAMING TO GUARANTEE DOOR HARDWARE PREP LINES UP WITH FRAMING HARDWARE PREP.
- *DOOR MANUFACTURER NEEDS FINAL APPROVED HARDWARE SCHEDULE BEFORE FABRICATION.
- *IF POSSIBLE, REQUIRE DOOR AND FRAME MANUFACTURER TO FACTORY INSTALL LOCKING, HINGING, TOP REMOVABLE HARDWARE MULLION, AND CONCEALED HARDWARE.
- *FOR ANY DOOR AND STOREFRONT OPENING CONCERNS OR QUESTIONS, FEEL FREE TO CONTACT OUR ARCHITECTURAL AND CUSTOMER SUPPORT LINE AT 1-800-806-DOOR.



FL-400-series
Maximum Security
Aluminum Flush Door
Specifications

Word File Version Available at our Website:

www.crossaluminum.com

Cross Aluminum Products, Inc.
1770 Mayflower Rd.
Niles, MI. 49120
Toll Free (800) 806-3667
Phone (269) 697-8340
Fax (269) 697-8348
www.crossaluminum.com
door@crossaluminum.com

Guide Specification

SECTION 08 11 16

ALUMINUM FLUSH DOORS

.....
Editor Comments: All contents of this product specification have been written using the Construction Specifications Institute (CSI) Master Format 2004 Edition. This specification has been edited and formatted to meet the CSI 3-Part Format. Page Format, Section Format, and the CSI Manual of Practice were used in the arrangement of this specification.

This specification is written by Cross Aluminum Products Inc. and includes the FL-400 Series Flush Plank Doors.

If necessary, apply sections for Glass and Glazing (section - 08 81 00), Sealants (section - 07 90 00).

Hardware may be specified in this section or in section - 08 71 00.

This specification was intended to assist in distinct job specifications. It must be reviewed and revised by the Architect or job specifier to meet project requirements and local building codes. Anything which appears in brackets [_____] reveals an option for a particular item or statement to be either omitted, included, or inserted to meet job specific requirements.

Editor comments have been provided throughout this section to help the Architect or job specifier make any necessary changes.

.....

SECTION 08 11 16

ALUMINUM FLUSH DOORS

PART 1 GENERAL

1.01 SECTION INCLUDES

- A. Cross Aluminum Flush Doors.
- B. Aluminum Door Fra

1.02 RELATED SECTIONS

- A. Section 04 20 00: Masonry (Frame Installation)
- B. Section 07 90 00: Joint Sealers
- C. Section 08 71 00: Door Hardware
- D. Section 08 80 00: Glazing
- E. Section 09 90 00: Field Painting

1.03 REFERENCES

- A. ASTM B 209 - Aluminum and Aluminum-Alloy Sheet and Plate.
- B. ASTM B 221 - Aluminum and Aluminum-Alloy Extruded Bars, Rods, Wire, Profiles, and Tubes.
- C. ASTM B 308 - Aluminum-Alloy 6061-T6 Standard Structural Profiles.
- D. ASTM E 283 - Determining the Rate of Air Leakage Through Exterior Windows, Curtain Walls, and Doors Under Specified Pressure Differences Across the Specimen.
- E. ASTM E 330 - Structural Performance of Exterior Windows, Doors, Skylights and Curtain Walls by Uniform Static Air Pressure Difference.
- F. ASTM E 331 - Water Penetration of Exterior Windows, Skylights, Doors, and Curtain Walls by Uniform Static Air Pressure Difference.
- G. ASTM E 1886 – Standard Test Method for Performance of Exterior Windows, Curtain Walls, Protective Systems Impacted by Missile(s) and Exposed to Cyclic Pressure Differentials.
- H. ASTM E 1996 – Standard Specification for Performance of Exterior Windows, Curtain Walls, Doors and Impact Protective Systems Impacted by Windborne Debris in Hurricanes.

1.04 SYSTEM DESCRIPTION

- A. System Performance Requirements:
1. Air infiltration: When tested in accordance with ASTM E 283, the air infiltration should not exceed .04 cfm per square foot of fixed area.
 2. Water Penetration: No water will pass through the entry system when tested in accordance with ASTM E 331 at a pressure of 6.24.
 3. Uniform Load Deflection: Entry system shall be tested in accordance with ASTM E 330: 3840 Pa or 80.0 psf positive and negative.
 4. Uniform Load Structural: Entry system shall be tested in accordance with ASTM E 330: 5760 Pa or 120.0 psf positive and negative.
 5. Missile Impact: Entry system will pass double impact from large missile; ASTM E 1886.

1.05 SUBMITTALS

- A. General: Refer to Submittal Procedures – Section 01 33 00
- B. Product Data: Include manufacturer's product information, including material, elemental construction, fabrication, and finishes.
- C. Shop Drawings: Include shop drawings relating to dimensions, fabrication, finish and installation.
1. Drawings should include the following:
 - a. Dimensions
 - b. Elevations with necessary detail keys
 - c. Entry system reinforcements (if applicable)
 - d. Fabrication and Finish
- D. Samples:
1. Color: Provide manufacturer's samples of standard and non-standard finishes.
 2. Door: Supply manufacturer's door sample presenting finish, interior insulation, and standard reinforcement components.
- E. Test Results: Offer any required test results for particular jobs. Accredited test reports will be available upon request.
- F. Manufacturer's Instructions: Provide all necessary instructions for installation including glazing, anchoring, reinforcement (if applicable), and optimum performance installation.

1.06 QUALITY ASSURANCE

- A. Manufacturer's Qualifications:
 - 1. Manufacturing process with contemporary inspection using neoteric checklist for optimum field performance.
 - 2. Manufacturing same product specified for over 25 years.
- B. Pre-Installation Meetings: Plan initial pre-installation meetings for job details and regional regulations.

1.07 DELIVERY, STORAGE, HANDLING

- A. Packing: Finished products shall be packaged securely with appropriate labeling for protection and product identification visible on packaging.
- B. Shipping and Handling: Deliver materials to site in original condition and packaging without any damage to packaging or materials.
- C. Unloading: Individually packaged products to be unloaded by hand truck or 2-person team lift (or more if needed) to avoid unnecessary damage.
- D. Storage and Protection:
 - 1. Store items indoors away from excessive amounts of moisture.
 - 2. Protect entry doors against damage from outdoor hazards and during the entire installation
- E. Waste Management: Refer to contact information apparent on packaging for appropriate recycling opportunities.

1.08 WARRANTY

- A. Warrant doors and frames to be free from defects and premature degradation of finish and door structure.
 - B. Warranty period will be ten years from the date of manufacture.

PART 2 PRODUCTS

2.01 MANUFACTURER

- A. Cross Aluminum Products Inc.,
Address: 1770 Mayflower Rd., Niles, Michigan 49120.
Phone: (800) 806-3667 or (269) 697-8340

Fax: (269) 697-8348
Web: www.crossaluminum.com
Email: door@crossaluminum.com

2.02 ALUMINUM FLUSH DOORS

- A. Product: FL-400 Series with required aluminum frames.
- B. Door Opening Size: [refer to drawings]
- C. Door Assembly:
 - 1. Door Stile: To be aluminum alloy 6063; temper to be T5 with a minimum 1/8" wall thickness.
 - 2. Stile Thickness: To be 1 3/4" thick tubular extrusion.
 - 3. Door Joinery: Joinery shall be 3/8" diameter zinc plated tie rods bolted through interlocking stiles. Minimum of 3 tie rods per door (where applicable).
 - 4. Top of Door: To receive added 1/8" reinforcement closer plate adhered to interior wall for door closer hardware.
 - 5. Top/Bottom of Door: To receive 1/8" thick cap for further seal and to trim the top and bottom of door.
- D. Pattern: [Fluted] or [Smooth]
- E. Insulation: Polyisocyanurate Rigid Foam

2.03 MATERIALS & ACCESSORIES

- A. Aluminum:
 - 1. ASTM B 221, alloy and temper to be 6063 T-5 or similar alloy and temper recommended by manufacturer for optimum finish results and consistency.
- B. Internal Reinforcement
 - 1. ASTM B 308, for structural aluminum.
- C. Fasteners
 - 1. Material: Aluminum, 18-8 Stainless Steel, or other non-corrosive materials compatible with items being screw applied.
 - 2. Exposed:
 - a. Type: Fasteners exposed will be Philips flathead fasteners unless provided by other supplier.
 - b. Finish: Fasteners to match appropriate finish on standard doors and frames.
 - 3. Concealed: To be standard according to manufacturer's standards.
- D. Weather stripping:
 - 1. Wool pile:

- a. Material: Solid Propylene Base with resilient fibers.
 - b. Color: Manufacturer's standard black color.
- E. Glazing:
 - 1. Door Glazing: Interlocking door glazing to be screw fastened and removable from interior with NORSEAL® V710 and/or V740 moisture seal foam tape applied to both interior and exterior sides of door. Exterior glazing to be non-removable.
 - a. Material: To be 1/8" thick extruded channels-6063-T5.
 - b. Color: To match finish of door.
 - 2. Frame Glazing: Exterior side Snap-in glazing. Frame gasket to be flush glaze extruded rubber compound; EPDM.
 - a. Material: To be aluminum extruded channels-6063-T5.
 - b. Color: To match finish of frame.

2.04 HARDWARE

- A. Hardware Preparation: To be fabricated at factory according to hardware templates provided.
- B. Hardware Installation: To factory install all applicable and supplied hardware to doors and frames.
- C. Hardware Reinforcement: To provide necessary reinforcement for proper longevity and hardware function; ASTM B 209 and/or ASTM 308.
- D. Hardware types:
 - 1. Butt Hinges
 - 2. Continuous Gear Hinges
 - 3. Pivot Hinges
 - 4. Closers
 - 6. Concealed Overhead Stops
 - 7. Push Bars
 - 8. Panic Exit Devices
 - 9. Pull Handles
 - 10. Mortise Locks
 - 11. Manual Flush Bolts
 - 12. Cylindrical Locks
 - 13. Dead Locks
 - 14. Electric Power Transfer
 - 15. Electric Strikes
 - 16. Position Switches
 - 17. Kick Plates
 - 18. Door Sweeps
 - 19. Thresholds
 - 20. Other
- E. Hardware Finish:

2.05 FABRICATION

- A. Processes:
1. Job Preparation:
 - a. Preliminary Analysis: Job drawings to indicate door types, sizes, vision lite configuration(s), and finishes.
 - b. Fulfill Custom Requirements: Follow through on any specific deviations from standard requirements.
 2. Assembly:
 - a. Product Operation: Measure, cut, and fabricate required materials for designated job.
 - b. Product Refinement: Smooth rough cut edges.
 - c. Arrangement: Place prepared structural fasteners inside door to conceal from view.
 - d. Reinforcement Preparation: To apply necessary structural and hardware reinforcement in beneficial areas of doors and frames where needed.
 3. Fitting:
 - a. Placement: Product materials to fit accurately in appropriate locations.
 - b. Alignment: Doors to be in proper alignment with intended elevations.
- B. Tolerances: Doors and/or frame elevations will not deviate from last revised and approved drawings.

2.06 FRAMING SYSTEMS

- A. Framing Members: Manufacturer's standard aluminum extruded profiles with required thickness for load support.
1. Vertical Jamb Sizes: [1 3/4" x 4 1/2"] [2" x 4 1/2"] [2" x 6 1/2"]
 2. Header Sizes: [1 3/4" x 4 1/2"] [2" x 4 1/2"] or [4" x 4 1/2"]
- B. Clips and Reinforcements: Manufacturer's standard high strength aluminum: ASTM B 221 and/or ASTM B 308.
- C. Fasteners and Accessories: Manufacturer's standard non-bleeding and non-corrosive material congruent to adjacent material.
1. Exposed Fasteners: To be stainless steel Philips flathead screws with appropriate finish: ASME B 18.6.4
 2. Concealed Fasteners: To be manufacturer's standard.
- D. Assembly:
1. Framing members are separate aluminum pieces cut to length and mechanically fastened from either spline or clip systems.

2. Joinery to be hairline.
 3. Sommer and Maca Dymonic or Dow Corning® 795 Sealants applied on applicable areas.
 4. Framing elevations to be identified according to final approved drawings.
- E. Anchoring:
1. Appropriate anchoring fasteners to be secured no more than 18" apart on entire frame opening.
 2. Frame headers to receive no less than 2 anchoring fasteners.
 3. Add extra fasteners where hardware and hinge may require more.
- F. Doorstop:
1. To be #CDM-32.
 - a. Wall Thickness: To be 3/16" thick for receiving applicable hardware.
 - b. Profile Height: To be no less than 5/8" high.
 2. Snap-in: Fits standard manufacturer's door jamb profiles.
 3. To receive weather strip around acting door leaves.
 - a. Wool pile: Solid Propylene Base with resilient fibers in a standard black color.
- G. Hardware Preparation:
1. Intramural Work: Hardware preparation according to hardware suppliers' templates.
 2. Field Work: Refer to manufacturers' installation instructions.
- H. Side lites and Transoms:
1. Factory-assembled to largest allowable shipping size.
 2. Identified in concealed locations according to final approved elevation numbers.

2.07 GLAZING

- A. Reference section Glazing accessories (08 85 00)
- B. Door Glass Stops:
1. Profile: 1/8" thick interlocking flush fit screw-applied extruded aluminum-stops with color matching door finish and removable from interior. Exterior glass stops to be non-removable.
 2. Standard vision lite sizes: [8" x 32"] [12" x 32"] [20" x 32"] [] x []

2.08 LOUVERS

- A. Style: Extruded Aluminum, mitered corners secured with reinforcing clips, inverted-Y design.
- B. Dimension: [x] [Refer to drawings]
- C. Finish: [Clear] [Dark Bronze] []

- D. Installation: Louvers to be factory installed and removable from interior only.

2.09 FINISHES

- A. Standard Anodic Finishes:
 - 1. Clear 204 R1: Architectural Class 11, AA-M12C22A31, 0.4 mils.
 - 2. Dark Bronze: Architectural Class 1, AA-M12C22A44, 0.7 mils.
- B. Available Anodic Finishes:
 - 1. Clear 215 R1: Architectural Class 1, AA-M12C22A41, 0.7 mils.
 - 2. Champagne: Architectural Class 1, AA-M12C22A44, 0.7 mils.
 - 3. Light Bronze: Architectural Class 1, AA-M12C22A44, 0.7 mils.
 - 4. Medium Bronze: Architectural Class 1, AA-M12C22A44, 0.7 mils.
 - 5. Black: Architectural Class 1, AA-M12C22A44, 0.7 mils.
- C. Paint Finishes:
 - 1. 70% Fluoropolymer (PVDF): AAMA 2605, ASCA 96, Kynar 500® or Hylar 5000®.
 - a. Fluropon®: 2 or more coat systems.
 - b. Trinar® Exotic Clear, Trinar® Metallic Clear: 3 coat system.
 - c. Duranar®: 2, 3, or 4-coat systems.

PART 3 EXECUTION

3.01 EXAMINATION

- A. Examine conditions for compliance with requirements for installation tolerances and other conditions affecting proper installation.

3.02 INSTALLATION

- A. Comply with manufacturer's instructions.
- B. Do not install damaged components.
- C. Install doors plumb, level, and square, with no warp or rack in frame.
- D. Hang doors with the following required clearances:
 - 1. Lock Stiles: 0.125"
 - 2. Between Meeting Stiles: 0.187" - 0.250"
 - 3. At Top Rails: 0.125"
 - 4. Between Bottom Rail and Threshold: 0.125" - 0.187"
- E. Fit joints to produce hairline joints free of burrs and distortion.
- F. Rigidly secure non movement joints.

- G. Install recommended anchors with separators to prevent metal corrosion and electrolytic deterioration.
- H. Seal joints watertight, unless otherwise indicated.
- I. Glaziers to provide necessary glazing shims for proper glass installation on vision lites and side lites. Reference section Glazing Accessories (08 85 00).
- J. Place thresholds in proper weather sealant.

3.03 ADJUSTING

- A. Fine-tune doors and hinges to operate properly without bind or sag.
- B. Adjust pressure settings on closers.
 - 1. For doors accessible to people with disabilities, adjust closers to provide a 3-second closer sweep period for doors to move from a 70-degree open position to 3 inches from the latch measured to the leading door edge.

3.04 CLEANING

- A. Immediately clean doors after installation.
- B. Avoid any harsh cleaners not specified on manufacturer's cleaning and care guide.

3.05 PROTECTION

- A. Follow Manufacturer's guide to cleaning and care for proper treatment on entrances for optimum longevity, function, and performance.

END OF SECTION